

Stainless Steel Facades

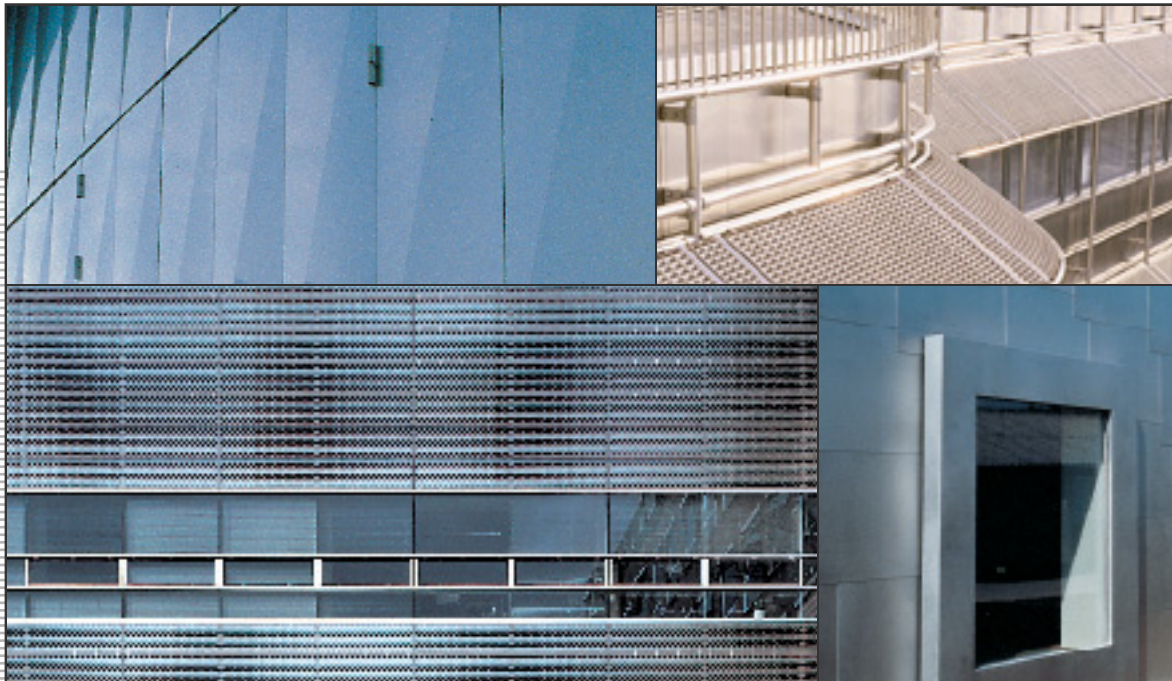

Euro Inox

Euro Inox is the European market development association for Stainless Steel.

The members of Euro Inox include:

- European stainless steel producers
- National stainless steel development associations
- Development associations of the alloying element industries.

A prime objective of Euro Inox is to create awareness of the unique properties of stainless steels and to further their use in existing applications and in new markets. To assist this purpose, Euro Inox organises conferences and seminars, and issues guidance in printed form and electronic format, to enable architects, designers, specifiers, fabricators, and end users, to become more familiar with the material. Euro Inox also supports technical and market research.

Editorial

Stainless Steel Facades

Second Edition 2002 (Building Series, Vol. 2)

ISBN 2-87997-002-4

© Euro Inox 2002

Editor

Euro Inox

Seat of the Organisation: 241, route d'Arlon
1150 Luxembourg, Grand Duchy of Luxembourg
Tel. +352 26 10 30 50 Fax +352 26 10 30 51

Executive Office:

Diamant Building, Bd. A. Reyers 80,
1030 Brussels, Belgium

Tel. +32 2 706 82 67 Fax +32 2 706 82 69

E-mail info@euro-inox.org

Internet www.euro-inox.org

Author

Martina Helzel, circa drei, Munich, Germany
(Concept, Text, Layout)

Peter Green, Munich (Translation)

Content

Euro Inox has made every effort to ensure that the information presented here is technically correct. However, the reader is advised that the material contained herein is for general information purposes only. Euro Inox, its members, staff, and consultants, specifically disclaim any liability or responsibility for loss, damage, or injury, resulting from the use of the information contained in this publication.

Introduction	2
Education and Research Establishments	4
Museums and Galleries	10
Administration and Commercial Buildings	16
Industrial Structures	32

Introduction

The development of stainless steel in 1912 provided architects with a new exciting building material with the ideal combination of high strength, excellent corrosion resistance, workability and a modern progressive image. For more than 70 years, stainless steel has provided the external weatherproof component of many of the world's tallest buildings from the Chrysler Building in 1930 to the Petronas Twin Towers in Kuala Lumpur in the 1990's. Advances in materials processing and finishing technology, particularly during the past

decade, provide the architect today with an increased range of stainless steels of higher quality, strength and with a wide selection of surface finishes available for the interior and exterior of buildings.

The purpose of this publication is to illustrate the use of stainless steel for the exterior cladding of buildings. Examples have been chosen of different building types in differing environments. We start with two buildings constructed in the 1960's, both of which illustrate the durable appeal of stainless steel.



Photo: David Cochrane, Sidcup

Although subject to heavy pollution, the stainless steel facade still shines in the sunlight after years without maintenance or cleaning.

Elephant & Castle Substation, London, England

Client: London Transport

Architect: London County Council

The substation was built in 1962 on a traffic island in the middle of a major road intersection in central London. Despite the heavy

pollution in this area, especially from traffic, the stainless steel cladding has not been affected and remains shiny and free of stains. No maintenance has ever been carried out and natural rainwater washing of the surface has prevented accumulations of airborne contaminants. The fine grit polished, pressed panels are in 0.7 mm stainless steel (EN 1.4401/ AISI 316).



CSM, Castel Romano, Italy

Client:

Centro Sviluppo Materiali, Castel Romano

Architects:

Franco Donato, Aldo Matteoli, Elio Piroddi,
Giulio Sterbini, Michele Valori, Milan

The headquarters and laboratories of the Centro Sviluppo Materiali (CSM) were erected in 1968 in Castel Romano near Rome. Although the complex is only four kilometres from the sea, the facades and window frames in satin-finished stainless steel (EN 1.4401/AISI 316) have successfully withstood the effects of the aggressive salty air without any apparent damage.

Ducts for services are housed inside the semi-circular vertical facade elements.

Photos: Centro Sviluppo Materiali, Castel Romano



Education and Research Establishments

CPE Lyon, France

Client:
 Département du Rhône, Lyon
 Architects:
 Pierre Vurpas & Ass., Lyon

The airtight appearance of the closed facade is completely transformed when the folding shutters are opened in different positions.

The extensions to the University of Chemistry, Physics and Electrical Engineering in Lyon vary considerably in their basic forms. However a unified architectural appearance was achieved by utilising the characteristic of the material finishes. The curving faces of the administration building, balconies and escape staircases are accentuated by the use of mirror polished stainless steel. The perforated stainless steel sheet cladding to the administration block serves as a form of sunshading for the large windows.

Photos: Erick SAILLET, Lyon

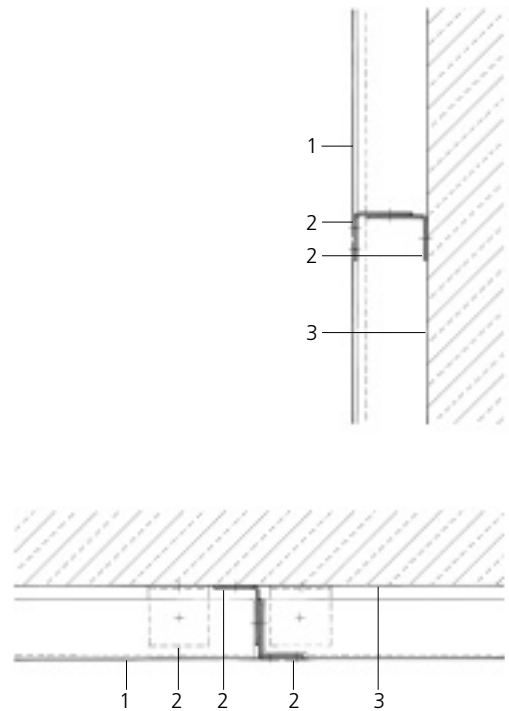

Vertical section · Horizontal section
 scale 1:10
 1 1.5 mm perforated stainless steel sheeting
 2 stainless steel angle, bent to shape
 3 concrete wall

The opening elements, set flush with the external skin, can be adjusted according to the angle of the sun. The escape staircases and the balconies are clad in the same material. The perforated stainless steel sheets are 1.5 mm thick and have visible fixings. The facade panels are fixed to the concrete walls with stainless steel angles.

The gas cylinders required for experimental purposes are housed on the balconies of the research building.



Horst Korber Sports Centre, Berlin, Germany

Client:
Landessportbund Berlin e. V.
Architects:
Christoph Langhof Architekten, Berlin



Photos: Wilmar Koenig, Berlin

This State Training Centre for Team Sports is divided into two sections. The bulk of the large hall is sunk into the ground, whereas the other, low-rise block with a curved front, is partly raised above the ground. The latter contains spaces for teaching, administration, a sports physician, a cafeteria and the sports hotel. The two sections of the complex are laid out with their long faces opposite each other. The route between them is dominated by the red colour of the shimmering stainless steel facades.

The electrolytically coloured stainless steel sheets have visible fixings. The colour tone changes according to the incidence of light.

The 1.5 mm pattern-rolled and electrolytically coloured stainless steel sheets are visibly fixed to horizontal and vertical top-hat sections, which are anchored by means of vertical angles and fixings into the externally insulated concrete wall.



The C3T is a research centre specializing in the development of new technologies for land transport. To distinguish between the various sections of the building, dark-blue painted concrete was used for the block housing offices and technical workshops and, folded stainless steel panels were used for the testing hall.

**Technology Skills Centre C3T,
Valenciennes, France**

Client:

University of Valenciennes

Architects:

X'TU Architectes

Anouk Legendre & Nicolas Desmazières, Paris



Photos: Jean-Marie Monthiers, Paris

The 900 x 2000 mm panels, folded back at the edges, have a brush-finished surface and are fixed with clips and rivets to omega sections. The diagonal fold in the panels, the lightly faceted form this creates and the curvature of the facade itself, give rise to a variety of reflections, interesting effects and textures.

The folds in the stainless steel sheeting increase the rigidity of the panels, allowing a thinner gauge to be used.



UFR Géographie, Villeneuve d'Ascq, France

Client:

University of Science and Technology, Lille

Architects:

X'TU Architectes

Anouk Legendre & Nicolas Desmazières, Paris

The oval structure, housing offices and experimental studios, is dissected by the linear library block, which penetrates it at ground floor level. The recessed plinth storey in black brickwork, the continuous strip windows and the stainless steel cladding to the upper floors lend the building a strong horizontal articulation.

The cladding consists of 900 x 500 mm stainless steel panels 1.5 mm thick fixed to galvanized steel channel sections with neoprene separators. This supporting structure is laid out in a grid-like pattern with 3 mm wide joints between the panels and is fixed to the concrete wall by means of angle brackets.

The strip windows and glass sunscreen elements accentuate the horizontal lines of the brush-finished stainless steel cladding.

Photos: Jean-Marie Monthiers, Paris

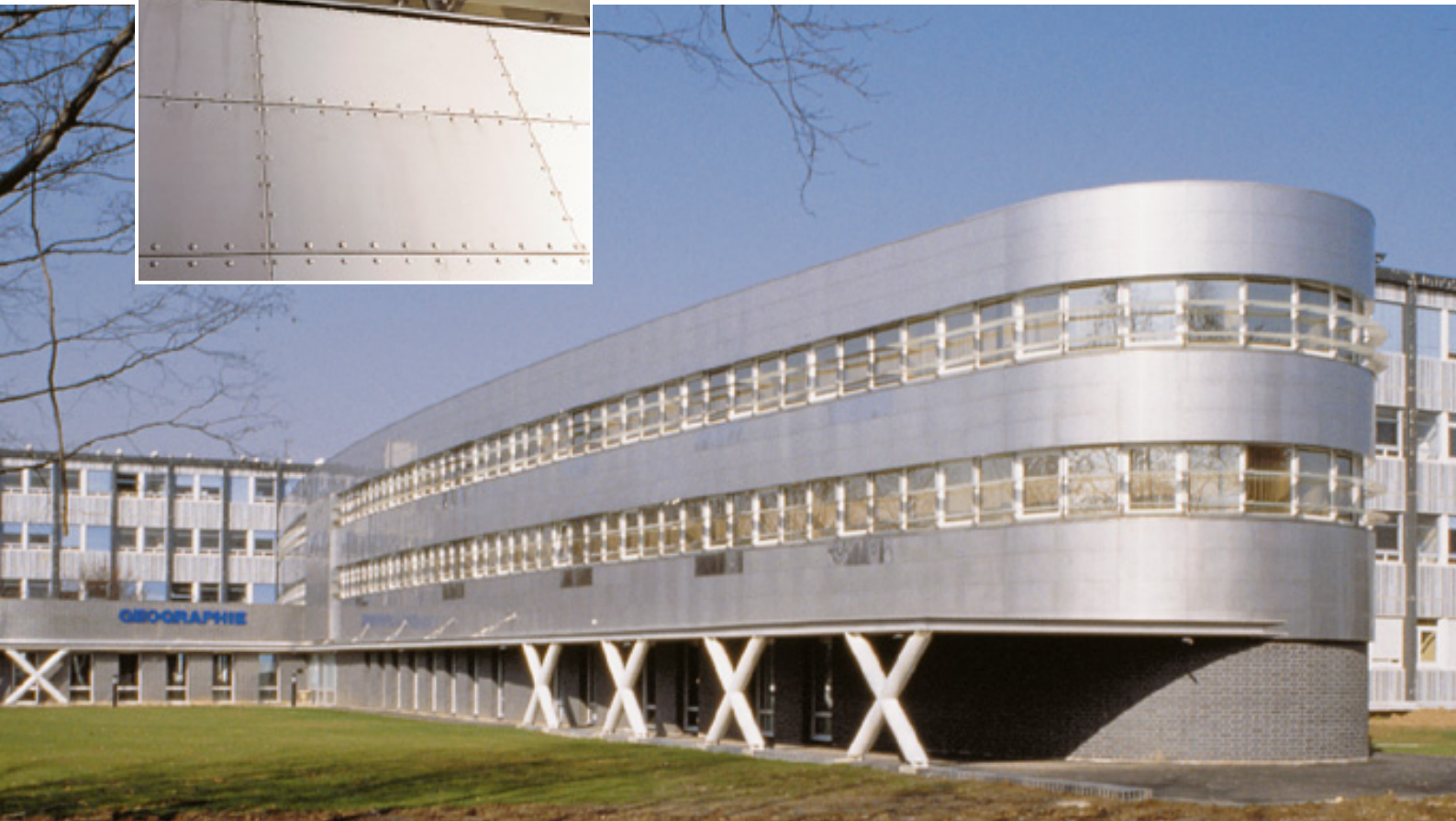



Medical Clinic Training Centre, Linz, Austria

Client:

Land Oberösterreich

Architect:

Prof. W. Holzbauer, Vienna

The 100-metre-long structure of the training centre screens the entire clinic complex from an autobahn to the south. The vertical strips of windows and the open escape staircases at the ends of the building formally separate the south facade from the rest of the structure. The choice of stainless steel was meant to differentiate the outer wall slab from the rendered facades to the rear. The tin plated stainless steel strips were laid with folded seams.

The impression of a free-standing wall slab is heightened by the tin plated stainless steel cladding.

Photos: Land Oberösterreich



The horizontal window strips and sunscreen elements, together with the folded seams of the cladding, accentuate the length of this block, which is interrupted by the glass facade of the entrance area.

Museums and Galleries

National Centre for Popular Music, Sheffield, England

Client:
Music Heritage Ltd., Sheffield
Architects:
Branson Coates Architecture, London

This unusual museum building resembles a spacecraft that has landed on the site – a former vehicle park. The four "drums" are occupied by two galleries (one for pop music history, the other for temporary exhibitions), a highly innovative sound studio, and an information centre for music production and

recording technology. The faceted facades continue up into the roofs, terminating in 11-metre-wide ventilation openings. Each of the drums has a structure consisting of 30 curved steel rib girders, ten of which support the concrete roof. The stainless-steel cladding is fixed to an aluminium supporting system, which is connected in turn to the steel ribs via adjustable channel sections. The abutments between the bearers and the stainless steel panels, which also serve the purposes of drainage, are sealed with silicone.

The four drum-like structures are tightly integrated into the urban fabric and enrich the heterogeneous roof-scape.

Photos: Graham Gaunt, London



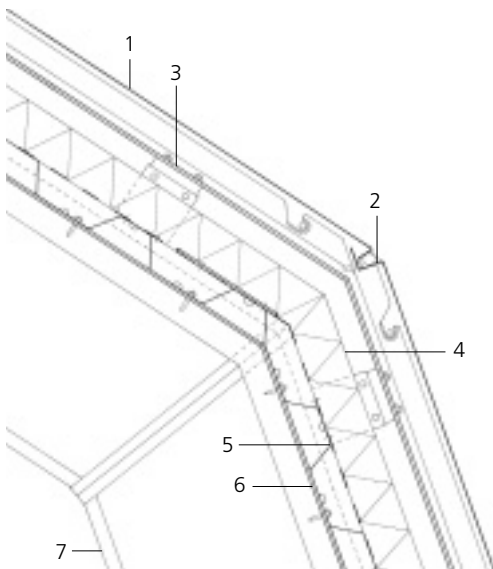
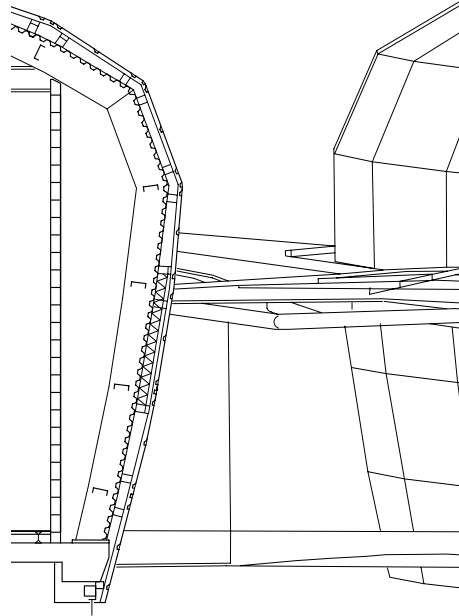

Section scale 1:100

Vertical section · Horizontal section scale 1:20

- 1 stainless steel panel, 2000 x 1500 x 2 mm, brush polished
- 2 silicone joint
- 3 extruded aluminium section fixed to channel bearers
- 4 60 mm mineral-fibre insulation
- 5 vapour barrier
- 6 trapezoidal-section ribbed metal sheeting
- 7 406 x 176 mm steel I-section

The entrance and foyer are formed by a large glass roof between the individual "drums".

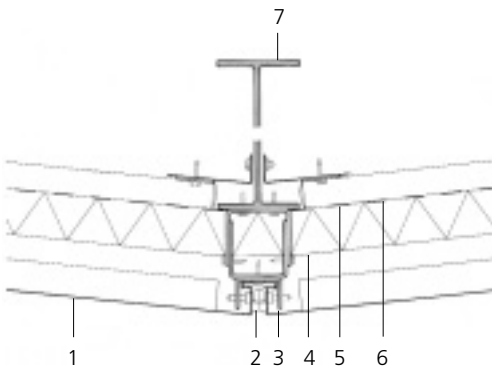

**Museum of Archaeology,
Saint-Romain-en-Gal, France**

Client:
Conseil Général du Rhône
Architects:
Chaix & Morel, Paris



Photos: E. Avenel, Paris (above),
Christian Richters, Münster (below)

Located on the Rhône opposite the town of Vienne, this museum of archaeology stands on the site of a former Roman settlement. The building is divided into two blocks and has a floor area of 12,000 m². The permanent collection is housed in a steel and glass structure raised on piers above the site of an archaeological excavation. It is linked via a bridge to a concrete structure

clad in stainless steel. This houses the offices, museum store, amphitheatre, cafeteria, further exhibition spaces and a workshop for restoration.

The cladding consists of 2 mm stainless steel panels 2230 x 1100 mm in size suspended from the supporting structure by means of metal sections welded to the rear face.

The simple elegance of the materials means that the building does not enter into competition with the exhibits or the historical location.



The museum, with its unusual saw-tooth profile, houses the works of two local artists. The exhibition spaces are filled with natural light, which enters through the window strips in the roof. The resultant form of the building is reminiscent of the rows of gable-end pitched roofs in the canton of Appenzell or the regular north-light roofs of industrial and agricultural buildings.

The gleaming, bead-blasted stainless steel "shingles" forming the external cladding recall the traditional weathered, grey wood-shingle façades of the surrounding villages.



The bead blasted outer skin of the building changes with the lighting conditions and the mood of the surrounding landscape.

The solid brick structure is fully insulated. The entire outer skin of the building – walls and roof – is clad with a total of 1,017 individual shingles in 585 different sizes, with a ventilated cavity to the rear. The 3 mm stainless-steel sheets are secret-fixed to a combination of wood battens and stainless steel sections.

Liner Museum, Appenzell, Switzerland

Client:

Stiftung Carl Liner Vater und Sohn,
Appenzell

Architects:

Annette Gigon & Mike Guyer, Zurich

The ample dimensions of the panoramic windows establish links between indoors and outdoors and also facilitate orientation within the building.

Photos: Heinrich Helfenstein, Zürich



Naturalis Museum, Leiden, Netherlands

Client:

HGB, regio West, Rotterdam

Architects:

Verheijen, Verkoren, de Haan, Leiden

The new Naturalis Museum in Leiden houses the entire natural history collection of the Netherlands. The museum comprises four buildings, each of which has its own distinctive facade cladding.

Most of the exhibits consist of organic substances and have to be kept in dimmed lighting conditions to preserve them from destruction. The department for skeletons is the only section of the museum that is extensively glazed and flooded with daylight. The facades to the other blocks are clad in stainless steel or terracotta tiles.

The individual sections of the museum complex are distinguished by different forms of facade cladding.



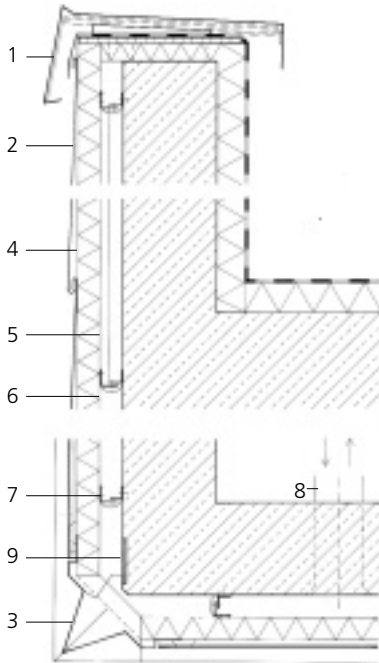

Vertical section · Horizontal section
Facade of storage tower
scale 1:20

- 1 stainless steel covering to upstand wall
- 2 0.7 mm stainless steel shingles 400 x 400 mm and 800 x 800 mm
- 3 stainless steel corner section
- 4 60 mm insulating panel
- 5 air cavity in area of upstand wall
- 6 60 mm air-conditioned cavity, divided into 600 mm wide ducts
- 7 2x stainless steel angles as divisions between air ducts
- 8 air extract and intake by means of conditioning plant
- 9 300 mm reinforced concrete wall



The 60-metre-high museum storage tower is enclosed entirely in stainless steel "shingles". Two different sheet sizes were used for this purpose – 400 x 400 mm and 800 x 800 mm – which resulted in a subtle facade texture not unlike the scales of a snake or a fish. The elongated block housing the offices is clad with angular stainless steel panels. Together with the integrated window strips, they lend this section of the development a striking, horizontally articulated structure.

Photos: Ger van der Vlugt, Amsterdam

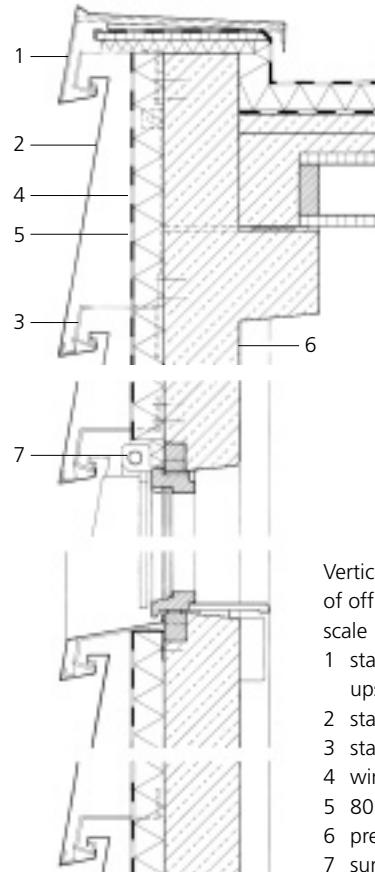

An air-conditioned cavity behind the stainless steel shingles and insulating panels helps to maintain constant temperatures in the storage tower.

Vertical section through facade of office block
scale 1:20

- 1 stainless steel covering to upstand wall
- 2 stainless steel panel bent to shape
- 3 stainless steel fixing strip
- 4 windproof membrane
- 5 80 mm thermal insulation
- 6 precast concrete element
- 7 sunscreen

Administration and Commercial Buildings

The perforated stainless steel sheeting forms a striking contrast to the traditional red engineering-brick facades.



Provincial Administration, Groningen, Netherlands

Client:

Gedeputeerde Staten Provincie Groningen, Groningen

Architects:

Bentham Crowell, Amsterdam

Photos: Jannes Linders, Rotterdam



A number of buildings in the city centre were demolished to create space for the new provincial administration of Groningen. The historical core, however, was preserved. A series of old and new buildings are laid out along a central access route. The outward design of the new buildings reflects the internal functions. The facades to the office areas are in red engineering bricks, which also establish a link to the existing fabric. The entrance area and the conference halls are clad in 3 mm thick stainless steel, which has been specially perforated and smooth polished.

Glass and perforated stainless steel sheeting in the entrance area create an impression of openness and light.

Administration Building, Coburg, Germany

Client:

HUK-Coburg property company, Coburg

Architects:

hpp, Hentrich-Petschnigg & Partner KG,

Munich

Designed to accommodate the more than 1,800 employees of an insurance company, the new administration building contains office space, a training centre, a meeting area, a canteen, central archives, an underground deliveries yard and a sports hall.

Depending on the situation, the facades consist of suspended clay-tile panels or folded stainless steel sheeting, with a ventilated cavity to the rear. The metal cladding units comprise a 1 mm layer of polished finish stainless steel press-formed, in specially made dies, into profiled shapes. The sheets are fixed to aluminium angles by means of bolts welded to the knuckles on the rear face. The angles, with bayonet-shaped punched slots, are invisibly hung in position in a drainage channel.

In addition to the facades, the maintenance balconies and air-extract stacks are also in stainless steel.

Photo: Manfred Hanisch, Mettmann



**North German Metal-Trades Association,
Hanover, Germany**

Client:
Norddt. Metall-Berufsgenossenschaft,
Hanover
Architects:
gmp, von Gerkan, Marg und Partner,
Hamburg

This administration complex consists of five blocks laid out parallel to each other and linked by a diagonal strip. The main blocks contain office spaces that can be freely divided up into units of various sizes. Between the office strips are single-storey structures housing archives, a library and conference rooms.

The facade areas and apron panels, clad in corrugated stainless steel sheeting, are divided into vertical bands of various widths.

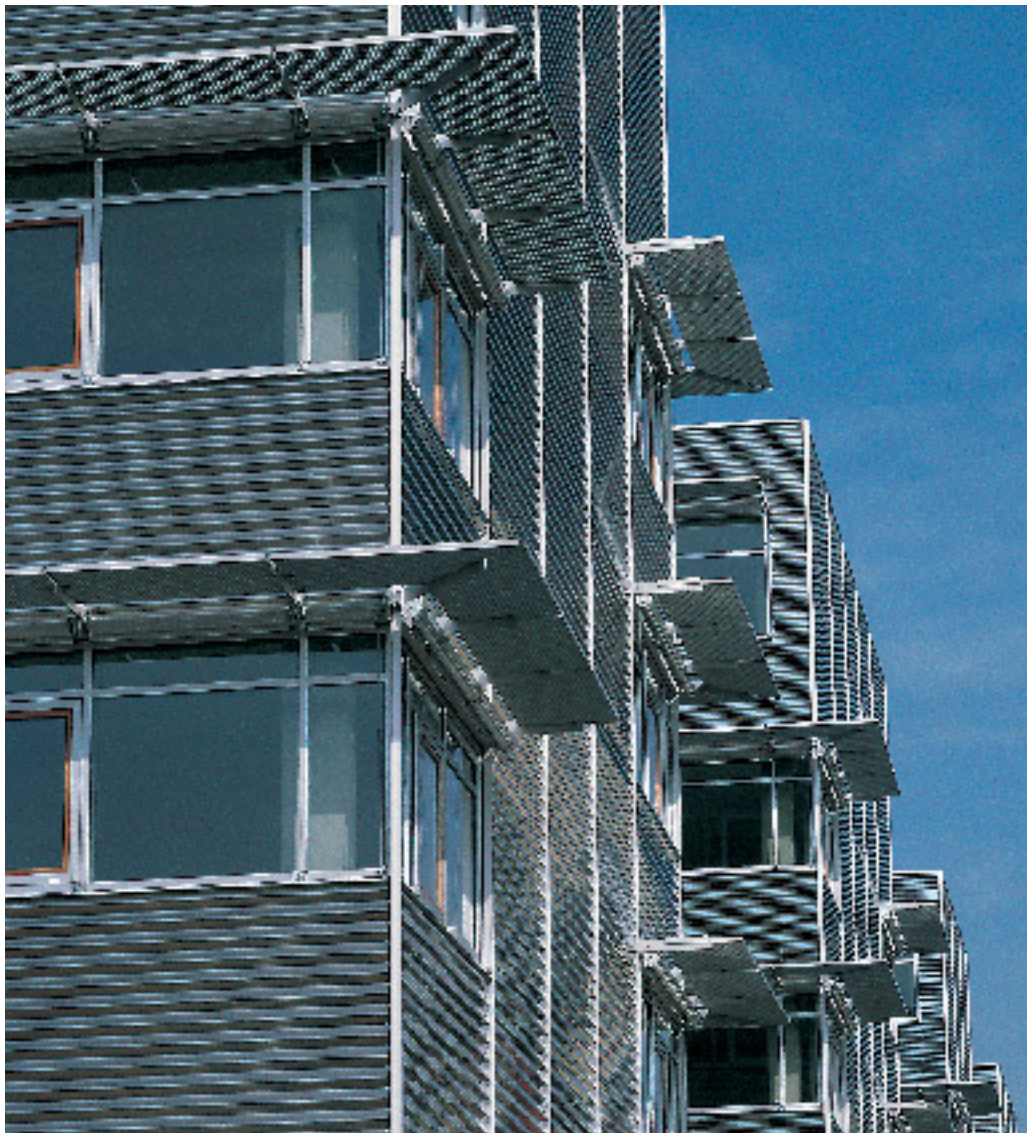



Corrugated stainless steel sheeting with visible stainless steel fixings at regular spacings.

The facade cladding of the six-storey office blocks is in corrugated satin polished stainless steel sheeting with a ventilated cavity to the rear. The 1 mm thick sheets are visibly bolted to extruded angles and T-sections, the layout of which lends the facade a vertical articulation that extends over all storeys.

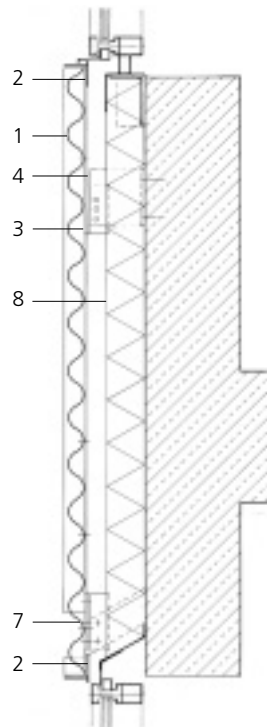

Vertical section · Horizontal section
scale 1:20

- 1 1 mm corrugated stainless steel sheets (corrugations: 40/100 mm) with satin-finished surface
- 2 60/70/6/3 mm aluminium horizontal T-section
- 3 60/120/6/3 mm aluminium T-section levelling strip
- 4 135/40/5 mm aluminium angle bracket
- 5 60/120/6/3 mm aluminium T-section vertical bearer
- 6 60/60/6 mm vertical aluminium angle edge strip
- 7 steel brackets for sunscreen elements
- 8 100 mm thermal insulation

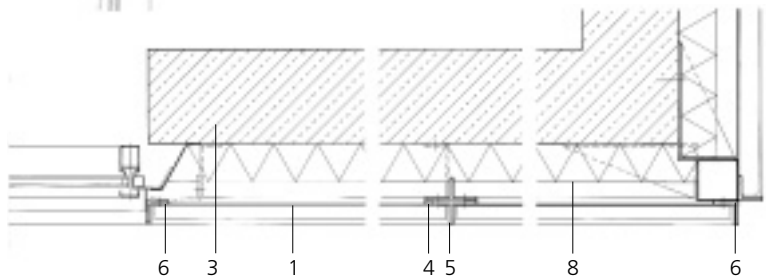

Photos: Werkfotos MN, Neustadt

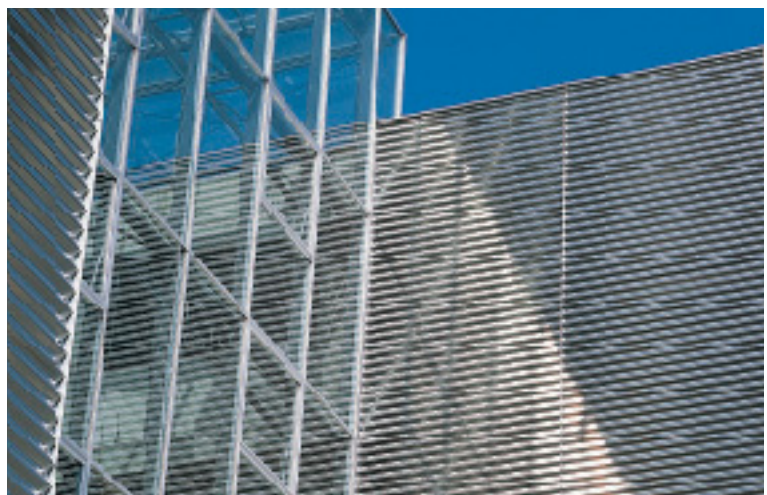

The stainless steel cladding is mirrored in the facade glazing, while the glass creates interesting reflections on the surface of the corrugated sheeting.

Factory Building, Gradignan, France

Client:
Boyer SA, Gradignan
Architects:
Luc Arsene-Henry & A. Triaud, Bordeaux

In contrast to the dark office block, which opens on to the landscape with large areas of glazing, the stainless steel cladding to the production hall reflects the surroundings in its surface.



Photos: Vincent Monthiers, Bordeaux



The products manufactured in this plant include stainless steel doors and tanks for foodstuffs and chemicals. The processing of stainless steel within the works is reflected outwardly in the appearance of the building, where trapezoidal-section profiled sheets – familiar to industrial buildings – were used for the cladding.

The load-bearing steel structure is clad internally with painted carbon steel sheet and externally with 0.8 mm mirror polished stainless steel sheeting.

The horizontal banding of the stainless steel cladding accentuates the low-rise form of the building.

Photo Studio, Salzburg, Austria

Client:

Stephan Kaindl-Hönig, Salzburg

Architects:

Prasser and Lutz, Vienna

This circular studio hall, based on the shape of a camera lens, was built as an extension to an existing single-family house. Through its unusual form and facade cladding, the studio enters into an exciting dialogue with its surroundings. The double-sided pattern-rolled and electrolytically coloured stainless steel panels were pre-curved and are braced by the angular standing seams. It was possible, therefore, to do without a horizontal supporting structure.



Photos: Stephan Kaindl-Hönig, Salzburg

As a result of its curvature, the stainless steel facade changes colour, depending on the incidence of light, from pale green or yellow to dark blue and violet.



Administration Building, Helsinki, Finland

Client:

Aspo OY, Helsinki-Herttoniemi

Architects:

Eero Eskelinen, Jan Söderlund, Helsinki

The lively form of this building and the choice of materials were influenced by a wide range of local factors. It is situated near a motorway to the north and adjoins an industrial area to the east; to the south, it is bordered by a marine oil terminal, and to the west by a coastal inlet.



The white ceramic cladding to the central section is attractively contrasted with the stainless steel facade.



The tall central block, a solid structure with a white glazed-brick facade, is laid out to an L-shaped plan along two roads. The lower elevations flanking it on each side are clad in stainless steel.

The street-side facades are articulated into two planes. Inset windows and the horizontal bands of stainless steel panels form a background, over which a series of tubes are fixed. These are aligned with the horizontal joints and the edges of the windows.

The curved, sea-facing south-west facade is complemented by a rigidly fixed sunscreen construction. The individual horizontal sunshading elements on the outside of the facade are supported by a structure suspended from the edge beams of the terrace storey.

Stainless steel tubes in front of the panels form a projecting plane that articulates the facade.



The stainless steel elements to the curved south-west facade have different surface finishes: the sleeves and sunshade gratings are bead-blasted; the tubular framing is bright polished and the cladding panels have a fine grit-polished finish.

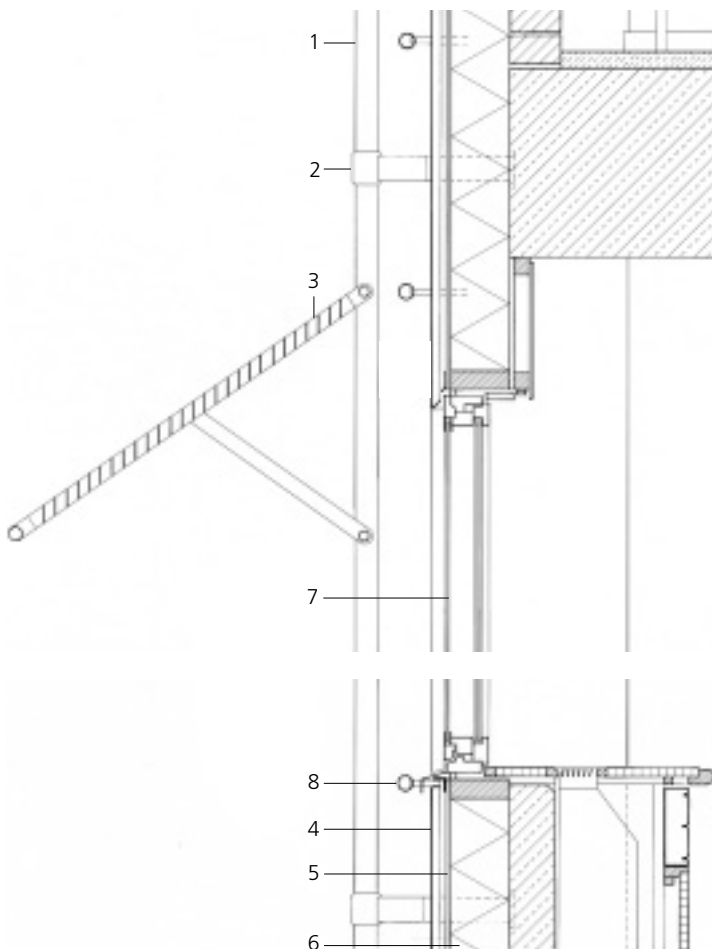

Vertical section through south-west facade
scale 1:20

- 1 sunshade framing: 60.3 mm dia. stainless steel tubes 3.6 mm thick
- 2 73 mm dia. stainless steel sleeve connector
- 3 stainless steel gratings, set at angle of maximum deflection
- 4 1.25 mm stainless steel panels with ventilated cavity to rear
- 5 fibre-cement sheets
- 6 150 mm thermal insulation
- 7 double-glazed casement
- 8 42.4 mm dia. stainless steel tube

Photos: Kai Nordberg, Helsinki



Bank, Biella, Italy

Client:

Cassa di Risparmio, Biella

Architects:

Enrico and Luca Villani, Vercelli

Situated in the centre of Biella, a small town near Turin, this complex accommodates the headquarters of a bank, with administration and management offices and a service centre. The massive projecting upper floor houses the computer centre.

Both the curved and the flat stainless steel sheets, 1 mm and 1.5 mm thick respectively, are fixed at one end only to allow for thermal expansion in the longitudinal direction.

The solid volumes of the upper floor, with the curving lines of their stainless steel cladding, are boldly cantilevered out above the glazed plinth storey.



On the upper floor, the rainwater drainage is concealed behind the stainless steel cladding.

Photos: Luca Villani, Vercelli



Housing and Commercial Development, Lucerne, Switzerland

Client:

SUVA Finanzabteilung, Lucerne

Architect:

Hans Eggstein, Lucerne

The building, which belongs to the Swiss Accident Insurance Institute, is horizontally articulated according to the various functions it accommodates, including shops, a bank, offices and housing. In its form and use of materials, the development responds to the influences of the location. On one side, it is exposed to a main road with heavy traffic; on the other side, in contrast, there is a calm, small-scale urban area. The sheet stainless steel facade cladding forms a unifying design element that is used throughout the complex.



Photos: Mario Kunz, Kriens

Behind the 3 mm smooth grit-polished stainless steel sheeting are stainless steel sections with visible screw fixings. These prefabricated elements are assembled by means of a special, concealed suspension system, resulting in a uniform jointing pattern with 20 mm-wide joints, giving the cladding panels sharp cut edges.

The semicircular head of the building with its projecting glazed balconies marks the end of the visual axis from a public open space and forms a pivot between the main traffic route and a small road to the rear.

On the rear face of the building, rendered and stainless steel facades create a design link with the existing developments in the area.

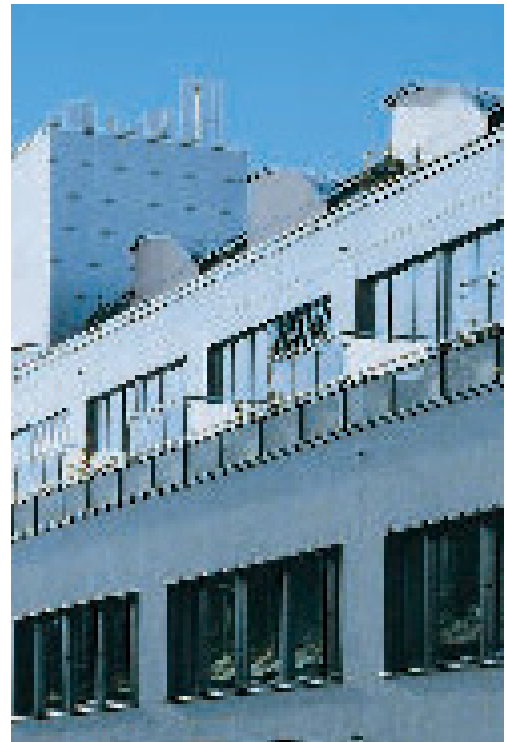



Photos: Anton Leimer, Biberstein

Office Building, Aarburg, Switzerland

Client:

Franke Holding AG, Aarburg

Architects:

Peter and Christian Frei, Aarau

This office development, with a two-bay layout, forms the western end of an existing industrial area. Access to the building is via a four-storey entrance hall. The floors are supported by two rows of walls along the corridors and cantilever out by five metres on both sides. At the outer edges of the building, between the floor slabs, are room-height areas of frameless glazing. Regardless of

its size, each office also has a room-height opening light in a stainless steel frame as a means of ventilation. In an otherwise anonymous glass and stainless steel facade, this creates an interplay of inlaid elements which reflect the internal spatial divisions on the outside. The end faces of the building are clad with stainless steel panels.



The external sunshading screens the glass facade without affecting the horizontal articulation of the building.

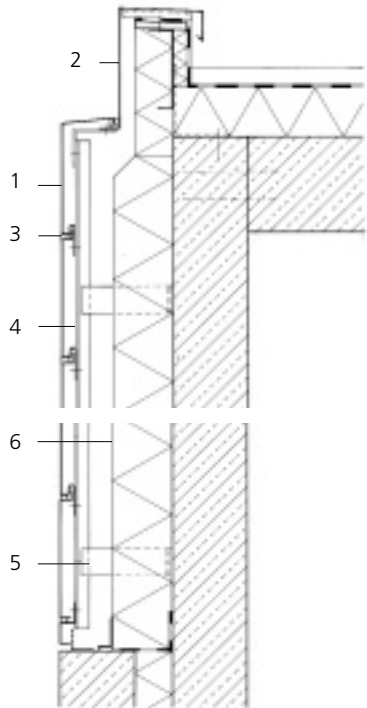

Vertical section scale 1:20

- 1 1.5 mm stainless steel facade panel with smooth polished surface
- 2 1.5 mm stainless steel covering to upstand with smooth polished surface
- 3 expansion joint section
- 4 aluminium angle or T-section vertical bearer
- 5 aluminium angle wall bracket with spring clip, on thermal separating layer
- 6 160 mm insulation

The facade demonstrates the potential of stainless steel construction reduced to an absolute minimum. The choice of the specific materials and forms underlines the clear concept of the building.

The escape staircase, set off from the main structure, is also clad in stainless steel. As a result of the facade construction, which consists of vertical Z-sections with spaces between them, the stair tower appears, at times, to be transparent and, at other times, fully enclosed.

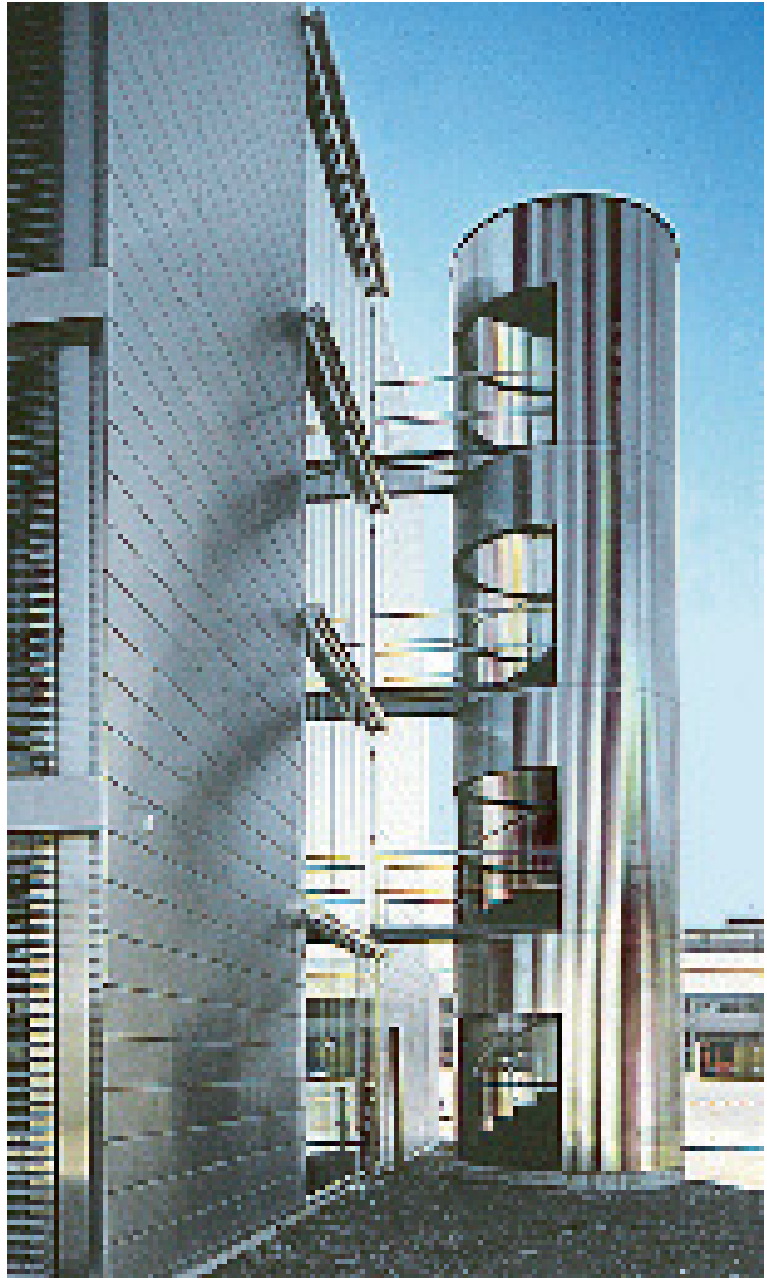

The escape staircase, set off at the side, is formally distinguished from the cubic shape of the main structure, even though it uses the same facade material.

Mapfre Tower, Barcelona, Spain

Client:

Mapfre Insurance Company, Madrid

Architects:

Ortiz León Arquitectos, Madrid



The Olympic Games in Barcelona led to a whole series of building measures that dramatically changed the face of the city. In the area between the harbour and the Olympic Village, a complex of buildings was erected that included a two-storey shopping centre, a four-storey office building and a 43-storey office tower.

The 153-metre-high tower is built to a square plan. The continuous, horizontal strip-window articulation on every floor lends the structure a clear-cut appearance and a sense of scale. The blue-glazed window strips are tilted outwards and cause the facade to visually vibrate with the reflections of nearby water and of the surrounding buildings.

Since the facade had to withstand the aggressive sea climate and, at the same time, create a positive image, stainless steel was chosen as the material for the peripheral maintenance balconies and the cladding to the parapet walls.

Glass and stainless steel are the dominant materials used in the facade of the Mapfre Tower, the landmark of the Olympic Village.

Photo: Ortiz León Arquitectos, Madrid

High-Tech Centre in Nieuwegein, Netherlands

Client:

Van Erkel Vastgoed Ontwikkeling B.V.,
Nieuwegein

Architects:

CEPEZED, Delft



Two four-storey buildings with concrete skeleton-frame structures are linked by a glazed atrium that contains the entire vertical and horizontal access, as well as the kitchens and sanitary facilities. The flexible office areas, which can be freely divided, have been leased to small and medium-sized computer and software firms.

The external walls are also in a form of construction commonly found in industrial

buildings: sandwich panels alternating with double-glazed window strips were assembled over the concrete structure. The panels consist of an outer layer of 0.8 mm fine polished stainless steel sheet, with a 140 mm layer of PVC foam insulation and an 0.7 mm layer of galvanized, white-painted sheet steel on the inside.

The entire service installations are housed in a separate four-storey technology tower.

Photos: Peter de Ruig, Den Haag



Zollhof, Düsseldorf, Germany

Clients:

KMR, Düsseldorf

Design architects:

Frank O. Gehry & Associates, Inc.,
Santa Monica, California

Architects responsible for execution:

BM + P Beucker Maschlanka + Partner GbR,
Düsseldorf

The insertion of this new, three-part complex upgrades an old industrial area on the Rhine. New urban spaces were created, and visual axes were opened up with views to the harbour pool and the river. The composition and



the execution of the scheme, with three different facade materials, create a highly original silhouette. The smallest section of the complex, situated in the middle, has a facade of stainless steel panels in which the terracotta-coloured brick facades to the south and a buff rendered facade to the north are reflected. As a result, the interplay of dancing



This remarkable building attracts attention to itself through its reflecting stainless steel facades, while the neighbouring rendered and brick facades adapt themselves to the new surroundings.

forms is heightened even further. The deliberate use of stainless steel is planned down to the smallest detail. The concave-convex alternation of bright annealed stainless sheets and curving lines is accentuated by the nature of the fixings. The distorted image is used as a design element.



Photos: Thomas Mayer, Das Fotoarchiv, Düsseldorf (left page)
Thomas Pauly, Brussels (right page)

The windows form a linking element between all three sections of the complex. They are integrated into a box-like construction that can accommodate itself to various situations.

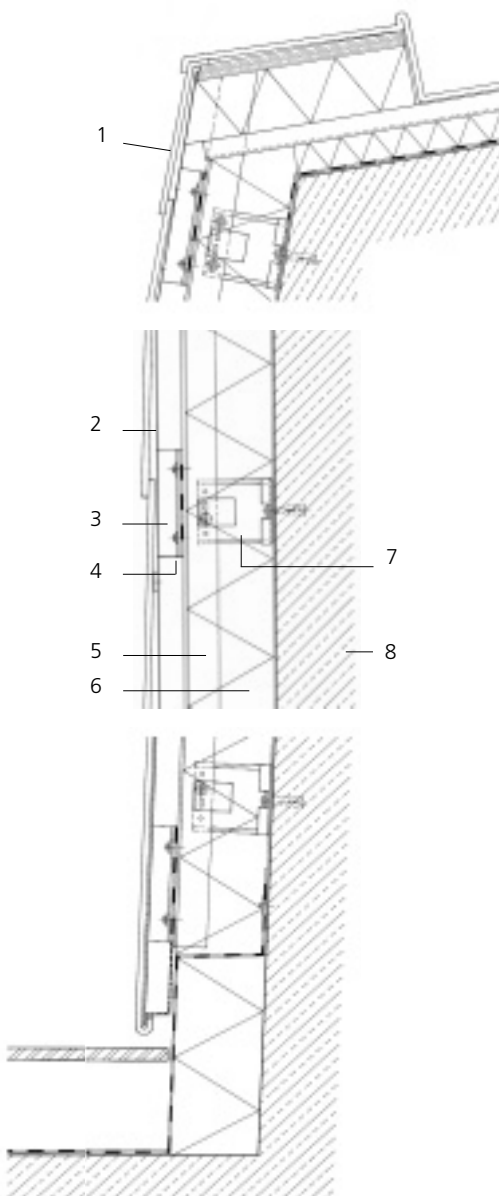

Horizontal section · Vertical section scale 1:10

- 1 0.4 mm stainless steel sheet panel cladding with stainless steel fixing tacks
- 2 0.88 mm Galvalume sheeting
- 3 100/25/0.88 mm stainless steel trapezoidal-section strip 250 mm long
- 4 250/3 mm aluminium strap on separating strip
- 5 63/45/1.5 mm Galvalume angle bearer
- 6 120 mm thermal insulation
- 7 wall bracket with distance piece
- 8 180 mm precast concrete unit

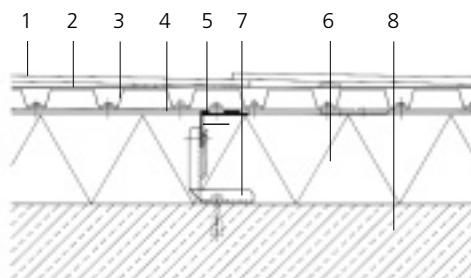

Industrial Structures

CNAM, Saint Denis, France

Client:
Ministère de l'Éducation Nationale
et de la Culture, Saint Denis
Architect:
François Deslaugiers, Paris



The large entrance door is opened by means of two hydraulically operated screw jacks.

The new building for the Museum of Technology contains storage space and rooms for restoration and research. Like a treasure chest, this technical structure houses objects of all sizes and materials, protecting them against the effects of moisture, light and fluctuations of temperature. With its singular appearance, this elongated building stands out among the surrounding storage structures. The facade merges in a seamless curve with the roof.

When closed, the 6-metre-wide and 4-metre-high entrance door is completely integrated into the convex curve of the stainless steel trapezoidal section sheet cladding.

The convex curve of the stainless steel facade sheeting continues round into the roof.

Photos: C. Demonfaucon, Chateaufort



Transformer Station, Cologne, Germany

Client:

GEW, Gas, Wasser- und Elektrizitätswerke,
Cologne

Architects:

Sandro Graf von Einsiedel + Ksp Architekten,
Cologne

The transformer station provides the Media Park and the adjoining urban areas with electricity. The dynamic roofscape, the silhouette

and the materials used are all designed to communicate the technical content of this building in an appropriate form. The blocks housing the transformers and coils are clad with basalt slabs. The neutral conductor plant is enclosed in silver-coloured, coated trapezoidal-section metal sheeting; the switching-gear block is clad with 1000 x 2000 mm stainless steel sheet panels with a rolled pattern surface. Suspended in front of the waterproof concrete walls, these thin metal panels are braced internally to reduce distortion and limit deflections.



The various functional areas are distinguished by the use of different kinds of facade cladding fixed over the reinforced concrete structure.

Photo: Lukas Roth, Köln

New Fire Brigade Headquarters, Berlin, Germany

Client:
State of Berlin, represented by Senate Administration for Building, Housing and Transport
Architects:
Fissler Ernst Architekten, Berlin

The gratings, which provide protection against the weather, are fitted flush with the facade and are integrated into the grid of shadow joints.



Externally, the buildings are differentiated in appearance. Internal functions are reflected in the facade design.



Situated in extremely heterogeneous urban surroundings, this headquarters structure – one of a complex of four buildings – has a special status. In addition to reflecting the internal spatial functions in the outer face, the development had to comply technically with strict requirements in respect of safety, durability and economic maintenance. The requisite protection against lightning and possible tension fluctuations, caused by power lines in the vicinity, was provided by the stainless steel facade with a rear ventilated cavity. In conjunction with the stainless steel roofing, this form of construction has the character of a Faraday cage in excluding electrostatic influences.

The 1.5 mm embossed sheet-metal facade panels, with a sound-absorbing coating on the rear face, were fixed to vertical stainless steel channel sections with stainless steel bolts. The supporting structure consists of continuous stainless steel angles and adjustable counter-angles. The channel sections are tied together with metallic bridging strips that serve as a means of lightning protection.

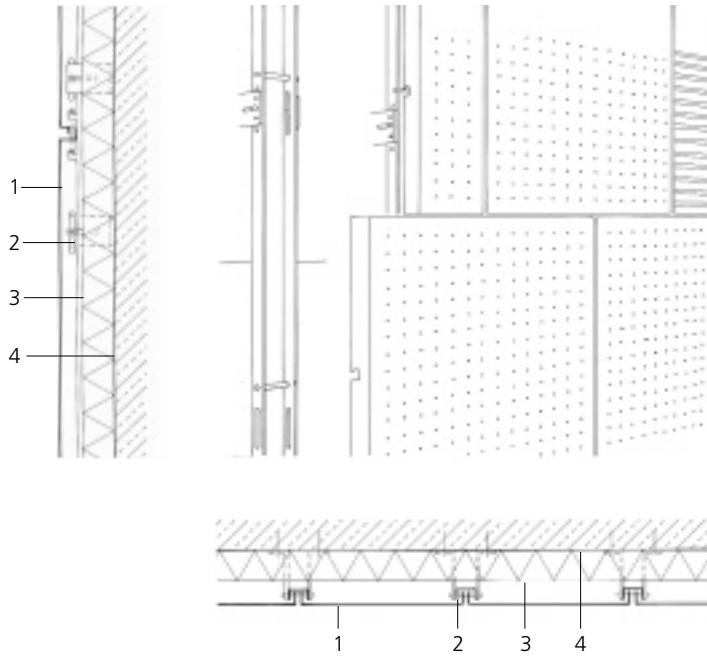

Sections through facade scale 1:20

- 1 1.5 mm stainless steel panels 400-1400 x 1765 mm, with all-round edge returns and embossed surfaces
- 2 stainless steel suspension strip and fixing angle
- 3 80 mm mineral thermal insulation
- 4 240 mm reinforced concrete

The varied articulation of the stainless steel panels lends the facade a lively appearance.



Photos:
Fissler Ernst Architekten,
Berlin

Thermal Power Station North, Salzburg, Austria

Client:
Salzburger Stadtwerke AG, Heizkraftwerke
Architects:
Marie-Claude Bétrix, Eraldo Consolascio,
Zurich

Despite its state-of-the-art technology and the use of stainless steel and concrete, the power station is more like a sculpture than a high-tech building.

The new Salzburg North power station is an energy supply plant equipped with the newest technology and designed to take account

of all relevant measures for environmental protection. The curved stainless steel roof and south face as well as the planar concrete walls – sloping at the northern end – are united to create a harmonious building image. The 4 and 5 mm thick stainless steel panels are butt-welded together and have a varied layout. The welded joints were subsequently chemically treated and burnished. The constantly changing curvature along the axes of both the roof and south facade ensures that none of the metal sheets used here are flat.

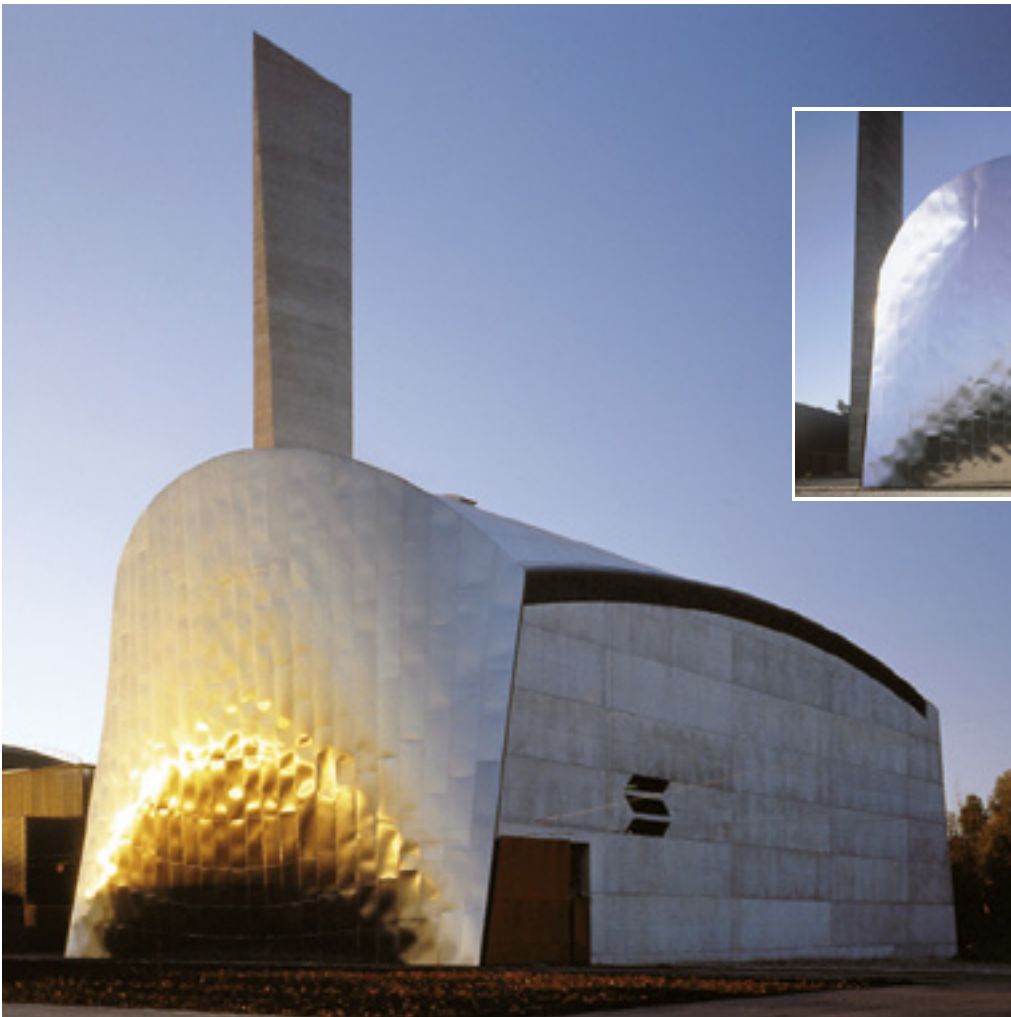

Photos: E. Hueber, N.Y.

ISBN 2-87997-002-4